





			±	

	JC		
	JA		



		±			±



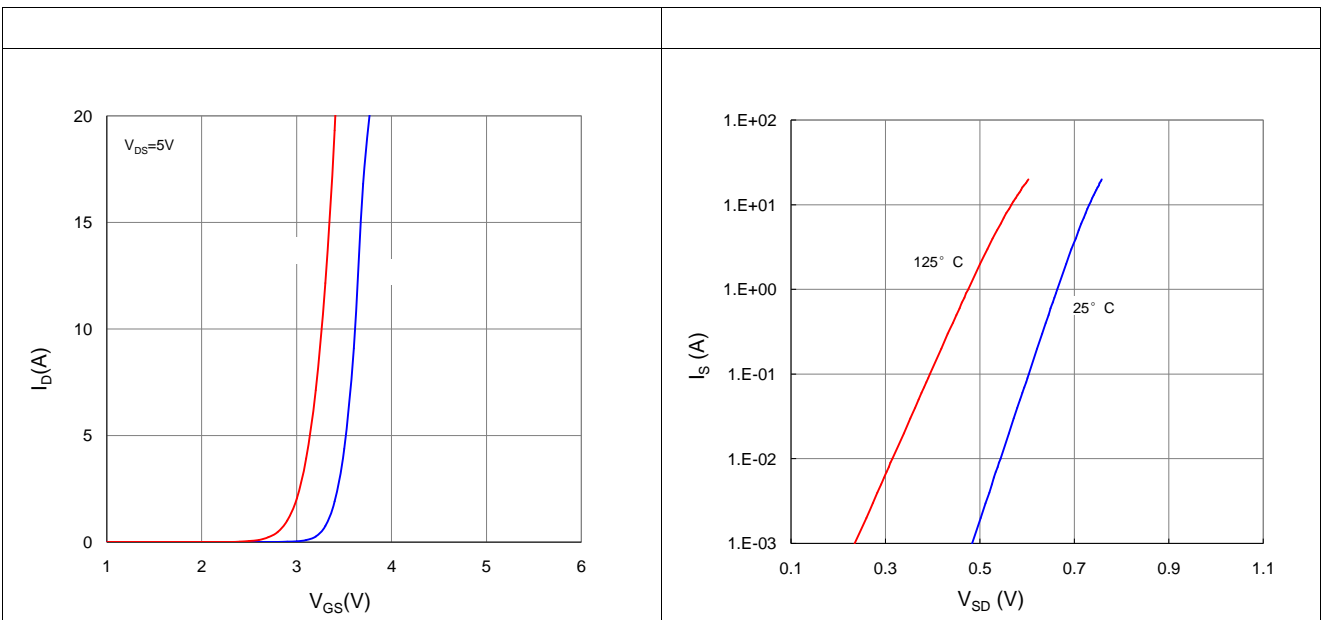
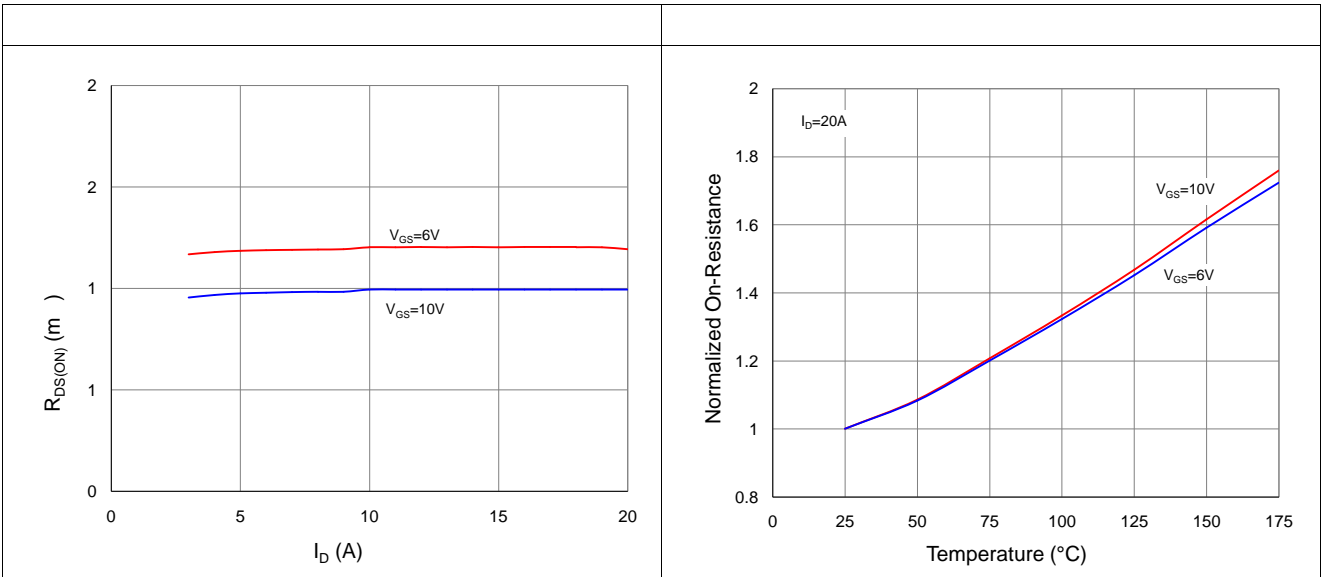
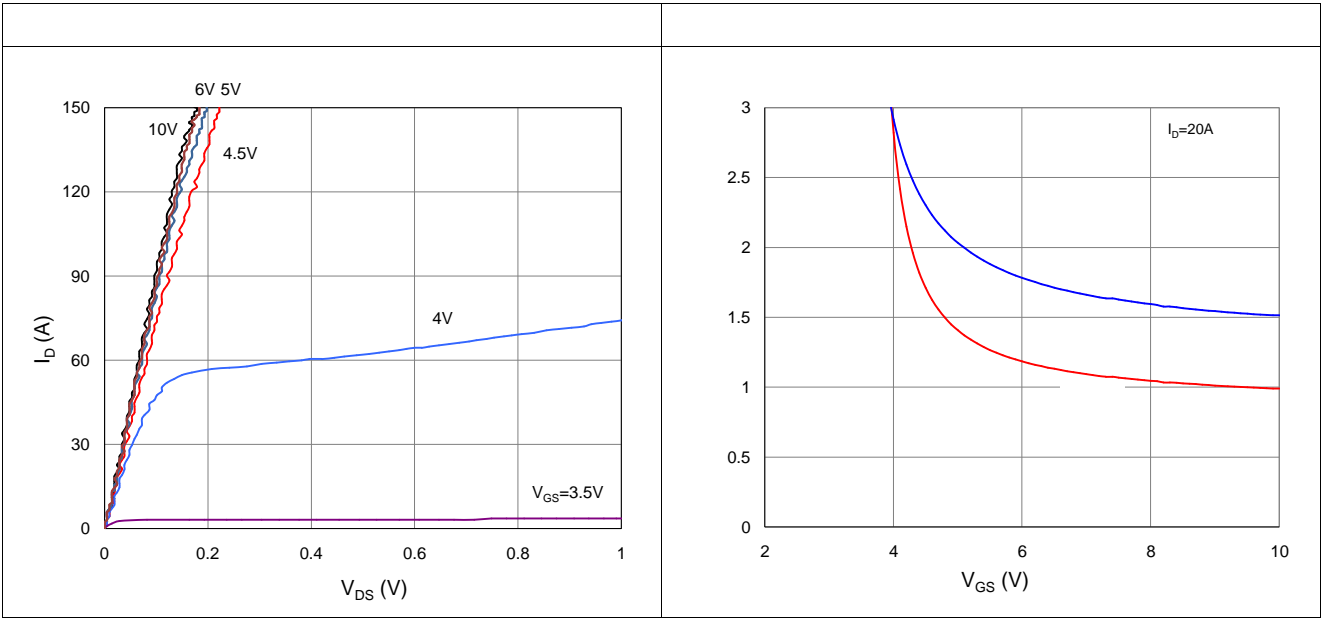

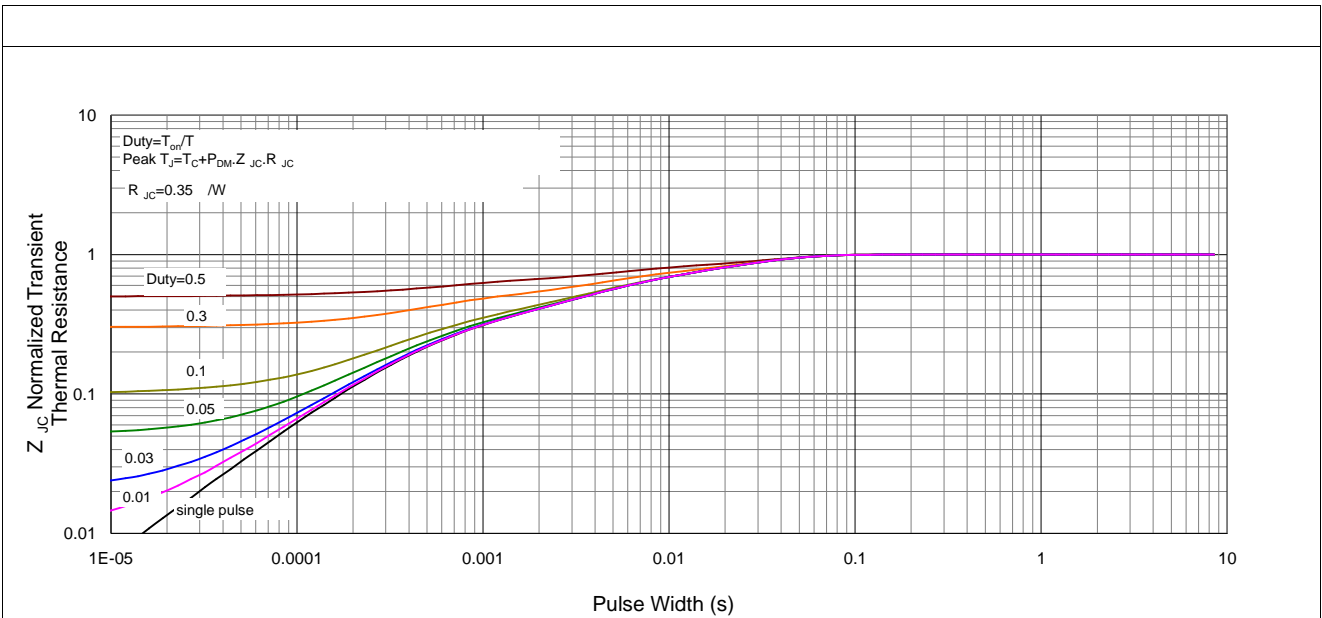
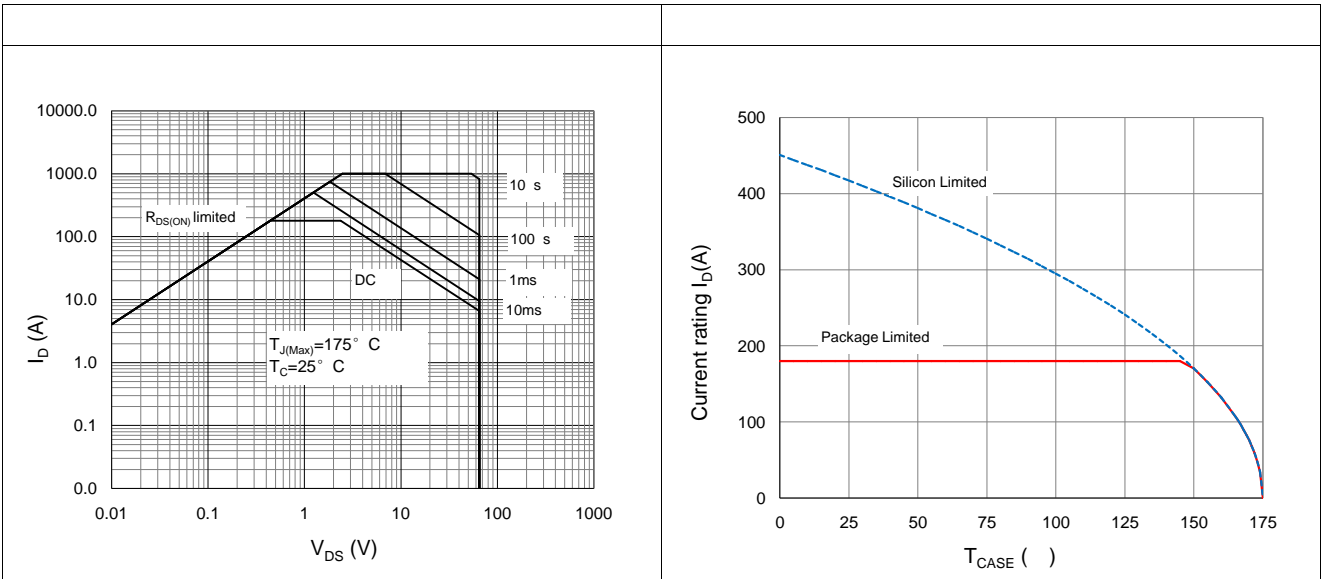
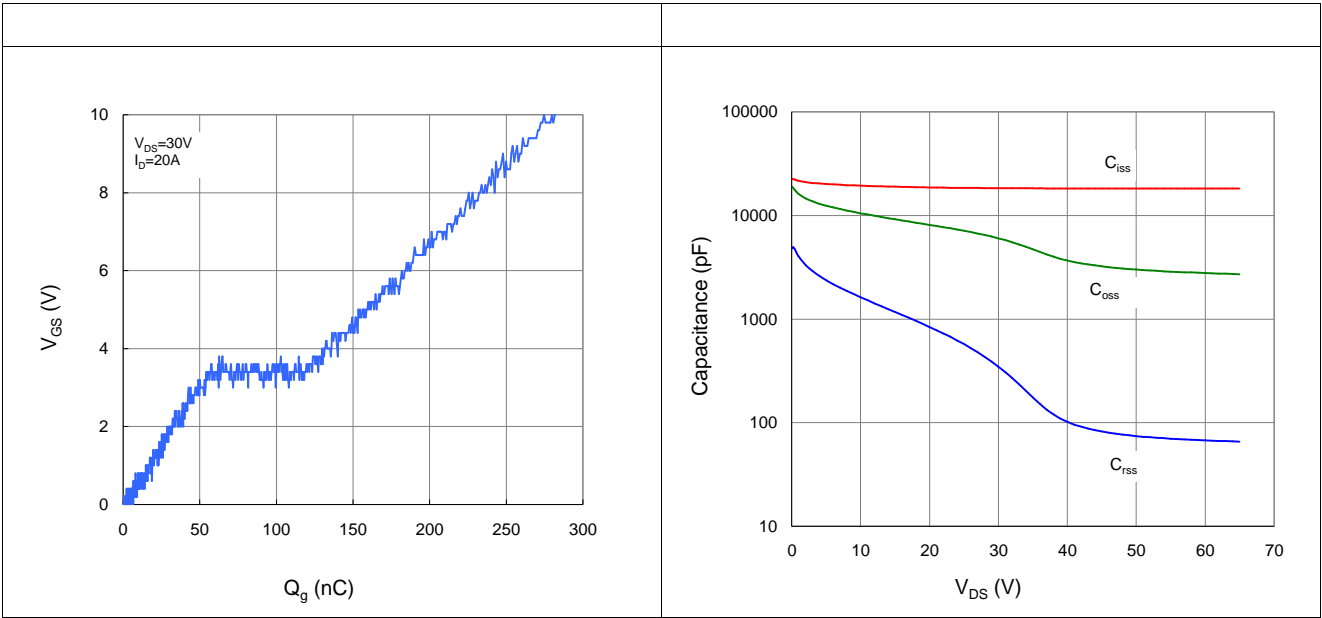



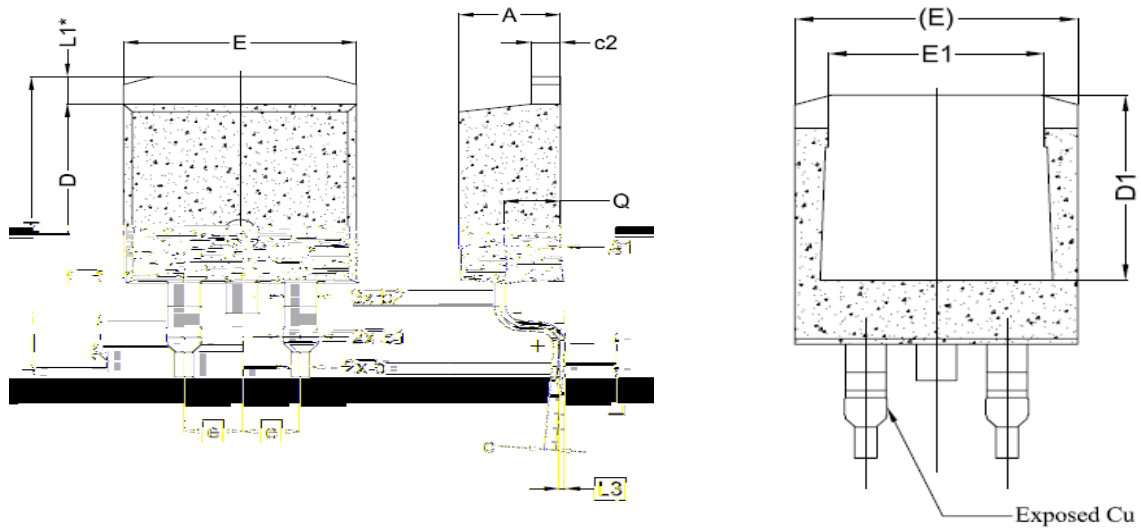

SYMBOL	DIMENSIONS		
	MIN.	NOM.	MAX.
A	4.24	4.44	4.64
A1	0.00	0.10	0.25
b	0.70	0.80	0.90
b1	1.20	1.55	1.75
b2	1.20	1.45	1.70
c	0.40	0.50	0.60
c2	1.15	1.27	1.40
D	8.82	8.92	9.02
D1	6.86	7.65	

Q	2-30°	2-48°	2-70°
L1		1.33±0.05	
L2		1.50±0.05	
L3		0.28±0.03	
H	14.67	15.01	15.68
L	1.78	2.32	2.78
b		0.54±0.03	
T1	0.38±0.04	0.77	0.99
E	5.98	6.07±0.05	6.16±0.05

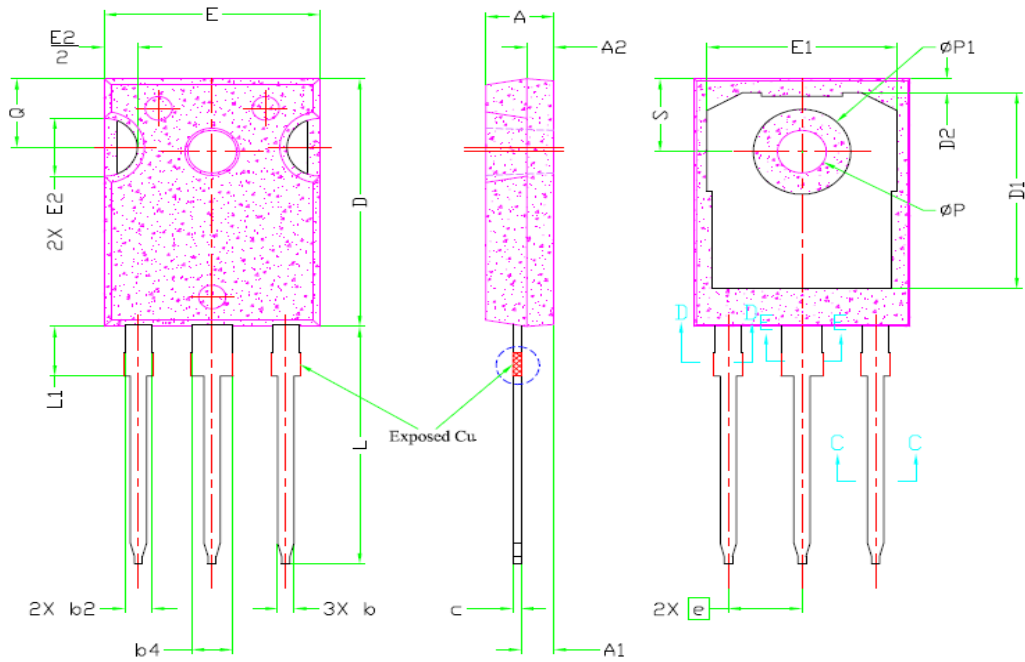

SYMBOL	DIMENSIONS			NOTES
	MIN.	NOM.	MAX.	
A	4.82	5.08	6.00	
A1	5.08	5.08	5.08	
A2	1.50	1.50	1.50	
B	4.12	4.12	4.12	
b1	1.27	1.27	1.27	
b2	1.27	1.27	1.27	
b3	1.27	1.27	1.27	
b4	1.27	1.27	1.27	
C	1.27	1.27	1.27	
D	1.27	1.27	1.27	
D1	1.27	1.27	1.27	
D2	1.27	1.27	1.27	
E	1.27	1.27	1.27	
E1	1.27	1.27	1.27	
G	1.27	1.27	1.27	
L	1.27	1.27	1.27	
L1	1.27	1.27	1.27	
L2	1.27	1.27	1.27	
L3	1.27	1.27	1.27	
L4	1.27	1.27	1.27	
S	1.27	1.27	1.27	
e	1.27	1.27	1.27	
øP	1.27	1.27	1.27	
øP1	1.27	1.27	1.27	